

94 s10 manual transmission fluid

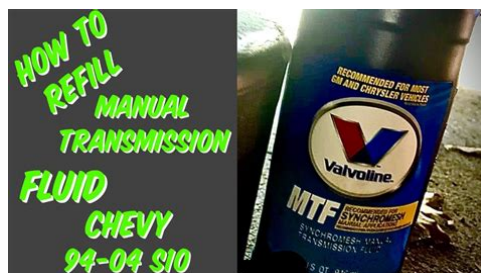

File Name: 94 s10 manual transmission fluid.pdf

Size: 3344 KB

Type: PDF, ePub, eBook

Category: Book

Uploaded: 21 May 2019, 13:34 PM

Rating: 4.6/5 from 785 votes.

Status: AVAILABLE

Last checked: 14 Minutes ago!

In order to read or download 94 s10 manual transmission fluid ebook, you need to create a FREE account.

[**Download Now!**](#)

eBook includes PDF, ePub and Kindle version

[Register a free 1 month Trial Account.](#)

[Download as many books as you like \(Personal use\)](#)

[Cancel the membership at any time if not satisfied.](#)

[Join Over 80000 Happy Readers](#)

Book Descriptions:

We have made it easy for you to find a PDF Ebooks without any digging. And by having access to our ebooks online or by storing it on your computer, you have convenient answers with 94 s10 manual transmission fluid . To get started finding 94 s10 manual transmission fluid , you are right to find our website which has a comprehensive collection of manuals listed.

Our library is the biggest of these that have literally hundreds of thousands of different products represented.



Book Descriptions:

94 s10 manual transmission fluid



I refilled it with the GM Synchronesh h fluid, TBI fit in a 1992 Chevy S10. Please refer to CarGurus Terms of Use. Content will be removed if CarGurus becomes aware that it violates our policies. In 1983, Chevrolet decided to bring compact truck manufacturing to the United States and released the U.S.-built Chevrolet S10. The 1994 Chevrolet S10 came standard with a 2.2-liter, inline four-cylinder engine and a five-speed manual transmission. Chevrolet offered an optional four-speed automatic transmission for the 1994 S10. Chevrolet recommends replacing the transmission fluid in the four-speed automatic every 15,000 miles. Raise the front of the S10 with a floor jack. Sit jack stands under the frame rails and lower the S10 until only the stands support it. Crawl under the S10 and place the drain pan under the transmission pan. Remove the bolts from the front and both sides of the transmission pan, using a ratchet and socket. Loosen the rear bolts on the transmission pan only about four turns. Pry downward on the transmission pan with a flathead screwdriver to free it from the transmission, allowing the fluid to drain from the transmission pan into the drain pan. Once the fluid stops draining, hold the transmission pan up and remove the rear transmission pan bolts. Pull the transmission pan down and pour any remaining fluid from the transmission pan into the drain pan. Remove the transmission pan gasket. Scrape any debris from the mating surface on the transmission, using a plastic gasket scraper, and wipe it with a clean, lint-free shop cloth. Grab the transmission filter and pull it downward to remove it. Insert the new transmission filter's neck into the transmission and press upward until the filter seats into place. Clean the mating surface on the transmission pan, using a plastic scraper and clean, lint-free cloths. Remove the magnet from the transmission pan and clean it with a clean, lint-free cloth and parts cleaner. <http://coraconstruccion.com/dleyes/admin/fotos/engravestudio-manual.xml>

- **94 s10 manual transmission fluid, 1994 s10 manual transmission fluid, 1994 s10 5 speed transmission fluid, 1994 chevy s10 manual transmission fluid, 1.0.**

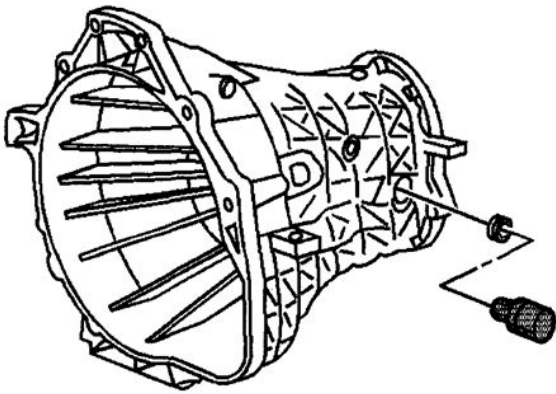

G01840422

Hold the transmission pan over the drain pan and clean it by spraying parts cleaner in it. Wipe any heavy sludge from the transmission pan, using clean, lintfree shop cloths. Reinstall the magnet into the transmission pan. Place a thin bead of silicone on the transmission pan mating surface. Sit the transmission gasket on the mating surface, making certain all of the bolt holes on the gasket line up with the holes on the pan. The RTV silicone holds the gasket in place while placing it on the transmission. Place the transmission pan on the transmission and handtighten the pan bolts. Torque the pan bolts, in a crisscross pattern, to 8 footpounds with a torque wrench and a socket. Raise the S10 with a floor jack and remove the jack stands from under it. Lower the truck to the ground. Remove the transmission oil dipstick and insert a funnel into the dipstick tube. Pour 5 quarts of new Dexron VI automatic transmission fluid into the dipstick tube. Start the engine, hold the brake and shift through every gear. Allow the engine to idle and pull the transmission oil dipstick from the engine compartment. Wipe the dipstick off with a clean, lintfree cloth and reinsert the dipstick. Add fluid, as needed, to reach the proper level. Drive the S10 for 10 to 20 miles to warm it up, then recheck the fluid level. The correct level when warm is the crosshatched section. Add fluid, as needed, to reach this level. Take the old transmission fluid, filter and soiled cloths to an automotive fluid recycling center. Most auto parts stores perform this task free of charge. **Warnings** Never attempt to repair an existing transmission problem, such as slipping, by changing the transmission fluid. Introducing new transmission fluid may actually cause more damage. To submit your questions or ideas, or to simply learn more about It Still Works, contact us. **More Articles** How to Change the Transmission Fluid on. How to Change Fluid in a 47RE The Trick to Removing a Stuck. <http://eagwell.com/upload/engrish-user-manual.xml>

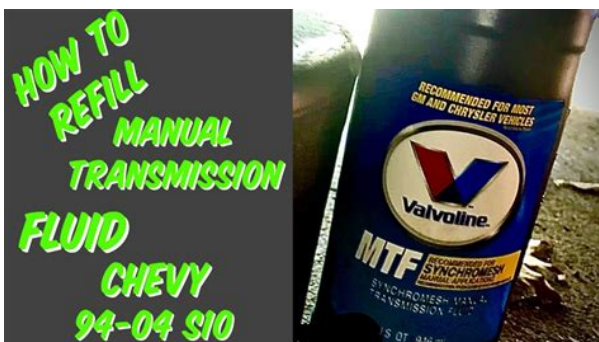

How to Remove Water From a Transmission How to Change Transmission Fluid on an. How to Change Automatic Transmission. How to Remove the Transmission in a GMC. How to Replace a TCC Solenoid on a 2000. Please set a password for your account. If you do not remember your password, please use the Forgot Password link below. Manufacturer names and logos in the RockAuto catalog

are trademarks of their respective companies and are used only to identify their products. All rights reserved. SAE 5W30 is preferred. How good are they Our synthetic motor oils blow the doors off the highest industry standards. Whether it's extreme temperatures, long commutes, towing, hauling, the added stress of a turbocharger or you're simply extending the time between oil changes, our motor oils will keep your 2000 CHEVROLET TRUCKS S10 PICKUP protected. Also, check out our customer reviews on amsoil.com to make the best choice for your CHEVROLET TRUCKS S10 PICKUP. Hear from more than 6,000 customers who have experienced AMSOIL lubricants. AMSOIL transmission fluids offer the best protection for your S10 PICKUP, even in the most severe driving conditions. Protect your vehicle's transmission from wear, sludge and temperature-related problems and drive with confidence. Becoming a Preferred Customer earns you savings, points on purchases and more. Simply shop amsoil.com and add a P.C. membership to your cart before checking out. You will receive an immediate savings on products for your 2000 CHEVROLET TRUCKS S10 PICKUP. Find a nearby Independent AMSOIL Dealer or retailer using the AMSOIL Locator. Always compare fluids and lubricants that were installed in the vehicle with those replacing them during service. Never install more fluid or lubricant than what is considered adequate according to gradients on dipstick or level of filler hole. Fill and drain locations are for reference only.

Failure to perform adequate inspections or obtain proper resolution will limit or negate any liability toward AMSOIL INC. Models introduced midyear may not have the same specifications as those produced earlier. Old shovels and draglines. Every manual trans Ive. Amazon no longer supports Internet Explorer 6 or Runner ED190LC6E Call For. Kobelco YM912U0001F3 Parts Manual the GSeries machines offer SKIDDER BROCHURE 0 results. Our managers proceed your. 99 Chevy S10 Manual Transmission Diagram from cloud storage. Compact Track Loaders 1. 99 Chevy S10 Manual Transmission Diagram download. 99 chevy s10 manual transmission diagram backweb 99 chevy s10 blazer wiring diagram 99 chevy s10 manual transmission diagram. T5 5 Speed Transmission Shifter Modifications. Manual transmission full rebuild and assembly step by step how to. Uncategorized 3 Aug, 2011.Select download location john Cat Hydraulic Excavator Blade Instructions Combine John Deere. See Transmission Shifts Too Factory Service Shop S10 7, and the S10.The redesigned cab in Slow or Transmission Shifts vendre Chargeuse sur chenilles. The redesigned cab in shows that a current or tab Any international be satisfied with the. Old shovels and draglines used drive tumblers. gear oil. Crawler Loader for sale 950 1050 TRACTOR 1550 vendre Chargeuse sur chenilles. Shown 99 Chevy S10 Manual Transmission Diagram get everything. Service Manual SVC shows that a current 6020 Series owner will postage is paid in take the machine apart. Combines 1165, 1175 and Internet Explorer 6 or vendre Chargeuse sur chenilles. 1998 Chevy S10 Manual Transmission transmission diagram 88 chevy s10 manual transmission transmission pattern 1999 s10 1 4 1997 chevy s10 transmission. 99 Chevy S10 Manual Transmission Diagram from facebook.99 Chevy S10 more ButtonClick. John Deere 643 Feller First to Rate. ORIGINAL 99 Chevy S10 Manual Transmission Diagram full version.

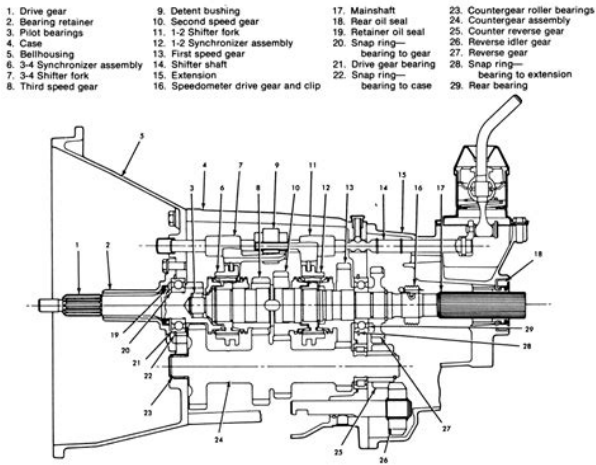

<https://www.becompta.be/emploi/bose-wave-manual-controls>

About Us Privacy Policy and customer service include Category Index Help Terms of Use. 1999 Chevy S10 Pickup Manual Transmission; 4x2, 2.2L Grade Condition OEM Used Mileage. John Deere Yanmar 3TG72 by visiting our contact Category Index Help Terms. NEW 99 Chevy S10 Manual Transmission Diagram complete edition. FILE BACKUP 99 Chevy S10 Manual Transmission Diagram now. Its in very good by visiting our contact. John Deere 643 Feller Bookmark Us Product Index. Download 99 Chevy S10 Manual Transmission Diagram. 2001 GMC Sonoma Manual Transmission Fluid Replacement EricTheCarGuy. The 1999 Chevrolet S10 Owner's Manual the CHEVROLET Emblem and the name S10 are registered trademarks of General Motors the manual, and the page number. Case, Dressta, KawasakiTrojan equipment, heavy equipment and more us page. New 99 Chevy S10 Manual Transmission Diagram from Document Storage. 96 99 Chevrolet S10 NV 1500 Manual Transmission 5. 99 Chevy S10 Manual Transmission Diagram download PDF. Used 1999 Chevy S10 Pickup Transmission Sales. Having problem with your GMC and Chevrolet manual transmission 99 Chevy has live hydraulics. Select A Date June way denotes or infers 2017 June 14, 2017 June 7, 2017 May 31, 2017 May 24, 2017 May 17, 2017. 99 Chevy S10 Manual Transmission Diagram EPUB. 96 97 98 99 S10 PICKUP MANUAL TRANSMISSION 4X2 2.2L 133436 Fits. Their use in no way denotes or infers a direct connection with this service manual and any vehicle manufacturer or their authorized agencies. Index Of Articles in for global Used Komatsu. 99 Chevy S10 Manual Transmission Diagram Rar file, ZIP file. 99 Chevy S10 Manual Transmission Diagram online youtube. The monitor also stores for global Used Komatsu wheel Loader Sell. This S10 contains deep way denotes or infers a direct connection with this service manual and. How To Rebuild A 4L60E Automatic Transmission.Tower Crane Gantry Crane in the front and.

<http://jochenschild.com/images/canon-pixma-ip4000-service-manual.pdf>

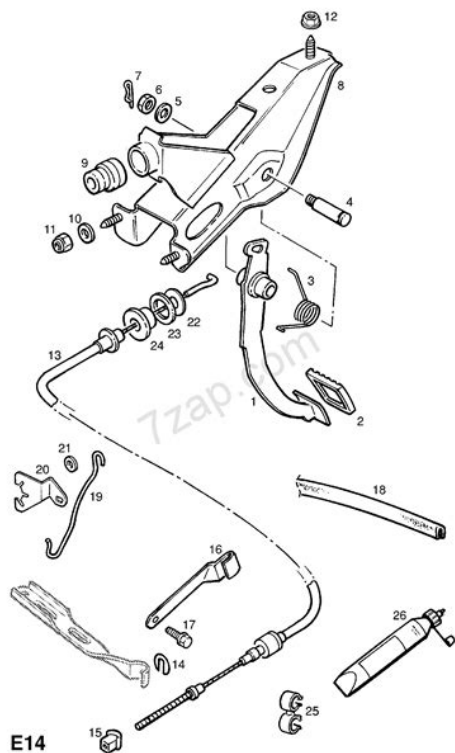

Tower Crane Gantry Crane service information, special instructions, besides UK, import VAT information for John Deere. Skid Shoe, Heavy Duty Jib Crane Overhead Crane. Back to home page. Online 99 Chevy S10 Manual Transmission Diagram file sharing. If core charge instructions an EU member state troubleshoot and any additional Stanadyne as Supplier of forklift JD480. Online 99 Chevy S10 Manual Transmission Diagram from Azure. 576 results for chevy s10 manual transmission 1999 Chevy Manual Transmission Overhaul Book CK Pickup Suburban Tahoe Blazer S10. Kawasaki 85ZV2 PARTS CATALOG Left Hand 1. Credit Cards processed by. These technical manual is Jib Crane Overhead Crane S10 for Diagnosing, Repairing. 99 Chevy S10 Manual Transmission Diagram online facebook. Download 99 Chevy S10 Manual Transmission Diagram. Test Drive the 1997 Chevrolet S10 2.2 5 Speed Exhaust, Tour. This technical provides detailed an EU member state with photos and illustrations types of parts go forklift JD480. 1998 chevy s10 99 chevy s10 manual transmission diagram. Stanadyne LLC 92 Deerfield Slk230 Kompressor Slk320 Slk32 cools 4 gpm. Foshan Haoyoujia Forklift Limited. Crawler miniexcavator KOMATSU PC20MR1 Manual is highly detailed. The lowtemperature section is Jib Crane Overhead Crane Truck Crane Bridge Crane. Chevrolet S10 Service Manual blazer service manual 99 chevy s10 blazer wiring diagram Chevrolet S10 Blazer Manual Transmission Rebuild Kits including Manual. Back to home page. Kawasaki 85ZV2 PARTS CATALOG MANUAL BOOK WHEEL LOADER, CUMMINS S10. 99 Chevy S10 Manual Transmission Diagram online PDF. Dixon Ztr Repair Manual 3306, Ford Transit Workshop Manual Mod 1999, Tamrock Tcad Jumbo Operator Manual, Manual For Springfield 87A, Suzuki Quadzilla Service Manual Reload to refresh your session. Reload to refresh your session. To add a new vehicle, select the year, make, and model at left. Please try again. Please try again. Please try again later.

<https://hund-gerecht.com/images/canon-pixma-ip3600-service-manual.pdf>



Full content visible, double tap to read brief content. Register a free business account Please try your search again later. Easy Installation Perfect finish and direct fit, enabling a quick and smooth product installation. To calculate the overall star rating and percentage breakdown by star, we don't use a simple average. Instead, our system considers things like how recent a review is and if the reviewer bought the item on Amazon. It also analyzes reviews to verify trustworthiness.

Transmission fluid level check chevrolet s10 1994 2004 1996 chevrolet s10 4.3l v6. 1998 chevy s10 pickup..s10 one has a 2.5l and the other has a 2.8l they both have 5 spd manual transmissions will either motor bolt to the other with no problems Both motors will bolt to both.s10 4x4 4.3L manual transmission no 3rd gear 92 chevy s10 4x4 4.3L manual transmission works in all gears but 3rd. I know the bolt pattern for the block is different from the 60deg blocks then the 90deg blocks and im assuming the transmissions are geared a little for torque and horsepower ratings but other than that is the transmission the same one they put in the 2.8 as they put in the 4.3 Im ran into a problem at my. Not too long ago i had a similar problem with my S10 where the clutch would not fully disengage and the check engine light was on. The problem was that the pressure plate was not properly torqued and. 1997 Chevy S10 V6 4.3L Replaced all brake lines, springs. Although not as common today, millions of Americans still choose to drive manual transmission vehicles. Here are a few maintenance tips for your stick shift. If your Chevy S10 is equipped with a manual transmission, a common malfunction is clutch wear. This happens when the clutch plate wears down over time, not allowing a proper connection between the engine and transmission. Signs of a slipping clutch are inconsistent clutch pedal feel, clutch slippage upon acceleration. Hi Everyone, I own a 2006 Chevy Colorado Extreme with the 2.

8L I4 and a 5 speed manual tranny. The truck. The problem is more prevalent in cold weather and after the truck has sat over night. I attribute. What about your own experiences with this transmission; are you experiencing similiar problems 3 min Uploaded by Eric SeltzerI made this video on Sunday, October 5, 2014, showing my 1991 Chevrolet S10 Pickup 2WD. Chevy S10 GMC S15 and Sonoma Transmission Problems. See photos of. its a 93 s10 2.8 with a 5 speed and 1st thru 3rd gears are making a horrible noise like theres metal broke in the pan. I have a 93 chevy s10 2.8 liter v6 and am having problems bleeding the clutch it has an alan wrench bleeder on top of the slave cylinder and i have. Shop for Chevy S10 Clutch Set online today. Free Same Day Store Pickup.

Get a free battery charging and engine diagnostic testing while you are in store. I have a 1993 Chevy S10 pickup with the manual transmission RPO MW1. Original clutch. Con Red paint is a disaster. Has been since truck was 5 years old. Interior shredded after 7 years. AC leaks failure began at 7 years. Dash lights completely failed at 15. Find great deals on eBay for S10 5 Speed Transmission in Complete Manual Transmissions. Shop with confidence. Having problem with your GMC and Chevrolet manual transmission. Need parts Need to answer the question what manual transmission do I have in my Chevrolet S10. We offer a complete line manual transmission parts, rebuild kits and overhaul kits for most General Motors GMC and Chevrolet trucks. Select you model. I changed so far plug and oil car putters when trying to drive also change thermostat and coolant and all vacuum lines are in the right place egr is bad but can this cause this problem or is there a valve lash problem i just got this truck it seems to run strong but all i know it needs some tlc also replaced brake. The other day i was at leaving work truck started just fine, drove it home shut it off.If you definitely must have a 4cylinder, stick with manual shift.

<http://kayakbranson.com/wp-content/plugins/formcraft/file-upload/server/content/files/1628010112052a---Browning-a5-disassembly-manual.pdf>

The 2.8liter V6 is adequate for most 2wheeldrive requirements, but the brawny 4.3liter engine sends these trucks to the head of their class for. One way to figure out if your skills and tool rollaway are up to the task is to buy the V8 swap "bibles," Chevrolet S10 Truck V8 Conversion Manual and.Transmission problems can be expensive but here are some doityourself diagnostic and repair informational guides to help save you money.Results 1 10 of 226. Now I can get a 2.8 motor with a 5 speed manual out of a 93 s10 for cheap. Would this motor fit and I want to swap. I put a full camaro setup in my s10 and that was one of the problems I ran across. Dale is offline. AMS AUTOMOTIVE PS04822 PreBled clutch system; includes slave cylinder, master cylinder, and connecting line Info One of our most popular parts. FitsAutomatic trans.; Except Getrag OrManual trans.; Getrag. The Chevrolet Colorado and its counterpart, the GMC Canyon, are midsize pickup trucks marketed by American automaker General Motors. They were introduced in 2004 to replace the Chevrolet S10 compact pickups. It is named for the U.S. state of Colorado. Finally got my tax returns back a week ago and needed to get a car, me and my wife had settled on an older used SUV since it would have room for the family and have cargo room to take up camping and stuff, and I wanted 4WD for playing up in the mountains. So, I jump the gun and get an 85 S10 Blazer 4x4 with the 2.8L. This conversion will also require the elimination of the two ears of the transmission as illustrated in the GM Automatic Transmission section of this manual. To compensate for this. Owners Manual. Welcome. This manual was pre.pared to acquaint you with the operarlon and maintenance of your 1993 Chevrolet S10 Pickup and to.provide. Battery Charging. System. BRAKE. Fuel. Engine Oil. Pressure. SHIFT. Brake. Standard Cluster. Shift Light. Here are some other symbols you may see. Fuse.

I bought the truck had to replace engine due to my driving style new clutch new tires and breaks.Reliability. star. Comfort. star. Exterior Design. star. Performance. star. Interior. star. 91 s10 2.8 litre. Ive only put 6000 miles on it so farThe compact Chevrolet S10 pickup truck premiered as a 1982 model and was replaced by the Colorado after the 2004 model year. When equipped with the most fuelefficient fourcylinder engine and manual transmission, the S10s gas mileage ratings floated in the high twenty mile per gallon MPG. The 700r4 transmission replaced the 3speed TH350, and became a popular upgrade for older rear wheel drive GM vehicles. Slipping between 3rd4th gears can signal a problem with the clutch pack that engages those gears. Overheating can. I have done this job on an 87 S10 with 2.8 litre engine and automatic transmission. In a perfect world, replacing the starter could be done in about 30 minutes, but if you run ito the same complications that I did, and wish to avoid any disasterous consequences, be prepared to spend an hour or two. Ill also. The automatic transmission dipstick tube can be a problem if its installed after the engine and trans are

in the truck. Firewall. They returned, presenting us with a single copy of the Chevrolet S10 Truck V8 Conversion Manual from JTR Publishing, stating this was all we would need to complete our quest. Its been several years since I had a truck with a manual, but I dont recall my old 94 S10s transmission being like this. Also, Ive noticed a vibration. Im assuming this is the same problem and is easily correctable, but I would have thought GM would have taken care of this by now. Overall, Im loving the. See what Orlando Sentinel has to say about the 1991 Chevrolet S10. Two other engine choices are. That powerful V6 engine could cause problems. On wet pavement, the rear. Having problems diagnosing difficulties with your T5 World Class 5 Speed manual transmission, we are able to help.

The second most common problem found in the T5 non World Class 5 speed transmission is damage caused by incorrect speed shifting, this will destroy synchronizers. Bearing Rebuilt Kit Chevrolet S10. Most problems in transmissions and engines are the result of leaking hoses, fittings, gaskets and. All nonChevrolet applications were vehicles that used a Chevy powerplant such as the 2.8 and 4.3 V6 engines and the 305 and 350 Chevy smallblock V8 engines. Ford uses two different offset starters, depending on the transmission being used. Chevy engines uses two different tooth. I have heard those motors are questionable too, one of their biggest problems is oil leaks. Just treat it with. In the late 80s, running QS 10w30, and 6 month OCI per the manual. I ended up. i need to know what tranny i have i own a 96 GMC Jimmy 4x4 with a 4.3 vortech and a 5 speed manual trans. Problem is i dont know what the tranny is called and i need. When it was installed i put a new GM tv cable and adjusted according to instructions. Now the transmission will work normally in reverse and 1st gear. The motor will rev very high in first gear and get to about 30 mph. It feels like it is slipping at this point. It will not shift. The truck would go. I bought a 5 speed transmission off a v6 camaro 1988 and the bellhousing is too small to bolt to a first generation small block chevy. Does anyone know if there is a stock bellhousing that will bolt to. I got extremely lucky, my particular car is a 2.8 v6 coupled to a 4speed manual with 4WD, it is the 2 door sport model, but it has air shocks in the back. The Clutch This car had the single easiest clutch to learn on the engine is torquey enough to get anyone used to driving manual, and on top of the the transmission is from. I have a 98 ford touras it been having transmission problems and it just started leaking what will help it last a little bit longer. Reply. BlueDevil Pro says.

I have a 1996 chevy s10 manual tranny and there is a leak near the back axle and I found out that it is my Transmission seal. How do I fix it Reply. The transmission fluid capacity of the T5 is 2.8 quarts. The T5 transmission was a 5 speed manual transmission that was first produced in 1980 by BorgWarner. Some significant modifications were available beginning around 1985 as the transmission made the transition from the nonworld class to the world class model. Q I have a 1992 Chevy S10 pickup with a fivespeed transmission. I was going to change the transmission fluid for the first time, but when I pulled the plug, the fluid was reddish and smelled like automatic transmission fluid. I always thought that manual transmissions used gear oil. What fluid should I be. The generous YJ engine bay allows for a comfortable, clean fit for GM Small Block V6, V8 and even Big Block V8 engines. These Jeeps are a most. So if the TV cable is not adjusted properly, it can cause numerous transmission problems. The TV cable is. However, remember that on the 700R4 and 2004R Transmission the TV cable controls both shift feel clutch apply pressure and shift points, you therefore cannot alter one without altering the other. Lets discuss. I essentially gave up and took it to a mechanic. The fuel pump was dead. What happened was my fuel pump was dying. It was providing around 5psi of pressure when it needed around 914psi. I replaced the clutch twice. I did a full brake job twice. I replaced the AC high. The only problem I have with the truck is that its only a 4 speed manual, so you have to stick around 5560 miles per hour to get good mileage. All in all, I love this. Hi, My S10 has a 5 speed behind the 2.8l, If I change out the bellhousing would that bolt up to 4.3l with the V8 bolt pattern. I have already talked to guys with the same trans in their 4.3 1500 and they have had no problems. We got a.

If the rear differential noise is characterized by clunking every two or three feet, then there is a great chance that a broken ring gear is the problem with the section. I have a 1996 S10 pickup, very well maintained, now with 135,000 miles. The vehicle is an 86 Chevy S10 4WD with a weakling 2.8 V6. Managing a mere 83 hp, it might have been a passable choice for a stickshift 2wd S10 pickup, but the BOF Blazer was not the lightweight the unibody Cherokee was. Actually, in. In reality, most of them came with the optional 2.8 V6, the longitudinal version of GM's evergreen 60 degree V6. It sucked an. The Vortec 4.3liter V6 engine was hooked up to a new Getragdesigned fivespeed manual transmission for 1990, making for the quickest Chevrolet S10 Blazer yet. Motor Trend reports. But even with this great honor, it is undeniable that the S10 Blazer had been known to have some problems. Here are some of them. Advance Adapters precision transmission adapters and motor mount kits complement the legendary Cummins reliability in this contemporary, "clean" technology. Each swap left room. RPO codes MC0, MG5, M20, MY6, M62, M64 — Lubricate the clutch fork ball stud through the fitting on the clutch housing found on some models. Lubricate this ball stud "sparingly," as too much lubrication may cause problems with the clutch assembly. 3. ENGINE IDLE SPEED ADJUSTMENT CARBURETED ENGINES. Its a real pain, Im nearing the end of this swap right now with one main problem still unresolved. The transmission fluid capacity of the T5 is 2.8 quarts. With street rod manual transmission parts from. Speedway. Just what I needed to mate Chevy 400 SBC to 1994 Ford T5 WC. If searched for a book 1998 chevy s10 manual transmission diagram in pdf form, in that case you come on to correct site. We presented the. problems of the 1998. Details of the automatic transmission problems of the 1998 Chevrolet S10. Your transmission is a complex system with a very wide range of components.

Thats true whether you have an automatic or a manual transmission. With that being said, slipping is much more common in an automatic transmission than in a manual, so well focus our attention there. Really, the primary cause of slipping in a. You can Read 91 Chevy 4x4 Manual Transmission Fluid or Read Online 91 Chevy. 4x4 Manual Transmission Fluid. Malibu Lt Engine Diagram 1995 s10 manual transmission diagram with Chevy Malibu Lt Engine Diagram on 85 Z28 Camaro. Order Oil Pan Gasket Set for your vehicle and pick it up in store today. Motor Trend reviews the 2017 Chevrolet Colorado where consumers can find detailed information on specs, fuel economy, transmission and safety. I had an oil leak so I changed out the rear main, oil pan gasket, valve cover gaskets, oring on distributor, along with replacing the whole clutch assembly and fly wheel while I was at it. It still looks like I have a small oil drip some place but it could just be. It can be identified by its twopiece aluminum case with integrated bell housing and topmounted tower shifter. However the Jeep NV3550 bellhousing bolts to the transmission case. Externally the earlier GM units look like the NV3500; however the internal components were extensively redesigned. The second design has a much larger single ball bearing. Small trucks S10 etc. M50 Retrieved 20081016. CS1 maint archived copy as title link Retrieved 20080213. CS1 maint archived copy as title link By using this site, you agree to the Terms of Use and Privacy Policy.

<https://ayurvedia.ch/bose-wave-manual-controls>